

# SWING DOOR OPENER

INSTALLING AND OPERATING INSTRUCTION

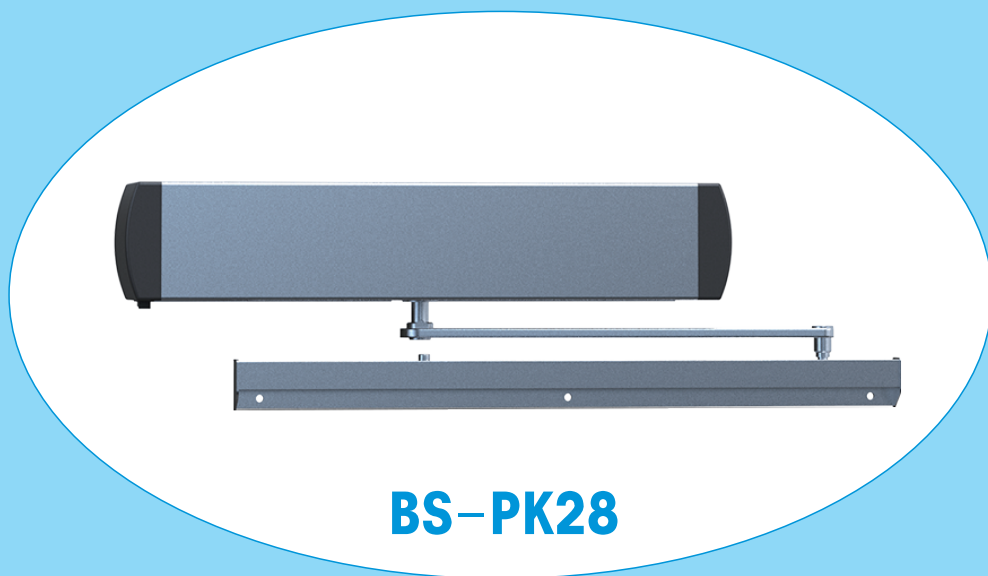

**BS-PK28**

PLEASE READ THE MANUAL CAREFULLY  
BEFORE INSTALLING AND USE

---

## WARNING TO THE INSTALLER AND SUER

- 1) CAUTION! For personal safety it is important to follow all the instructions carefully. Incorrect installation or misuse of the product may cause serious injury to people .
- 2) This product must be installed, debugged and maintained by professional and qualified personnel.
- 3) The power supply voltage must match the design requirements of this product and comply with electrical safety regulations.
- 4) This product was designed and manufactured strictly for the use indicated in this document. Any other usage not expressly indicated in this Document, may damage the product and/or be a source of danger.
- 5) The company is not responsible for losses caused by improper use .
- 6) Before carrying out any work on the product, turn off the Power supply.
- 7) This product must be equipped with an independent 6 A circuit breaker.
- 8) Do not make any alterations to the components of the product (Opener and Accessory).
- 9) Keep the instructions in a safe place for future refaerence.

## 1.Main parts

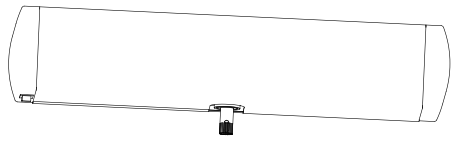

PK28,swing door opener

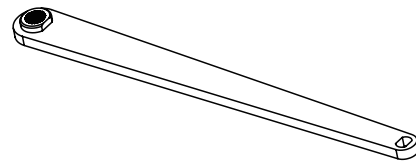

The main rod

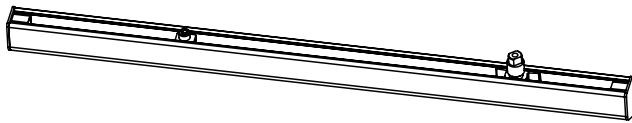

The pull rod (option)



Transmitter

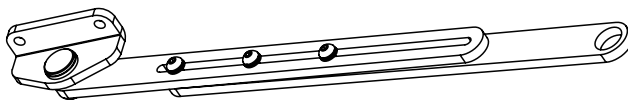

The push rod (option)



Screws

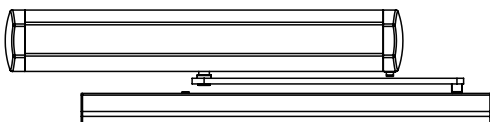

The opener with pull rod

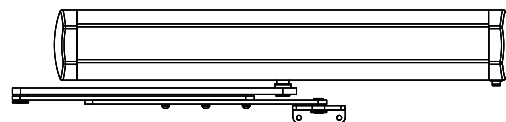

The opener with push rod

## 2.Dimensions

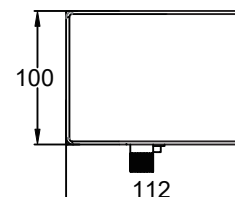
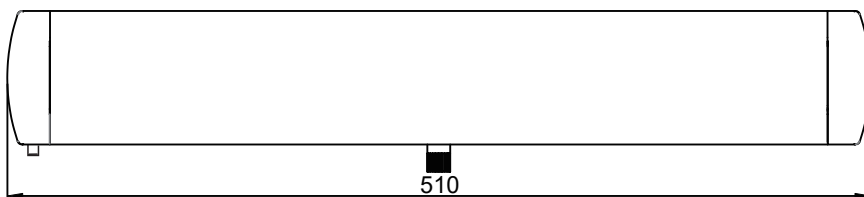

### 3. Technical Data

Power supply	AC220V±10% 50HZ
Power of motor	24VDC/40W
Rpm of motor	1800RPM
Open/close time	3-10S(adjustable)
Maximum opening angle	120°
Maximum door width	1200mm
Maximum door weight	120Kg
Working temperature	-20 °C ~ 50 °C

### 4. Features

- \* Pull or push to activate the door opener operation.
- \* Automatic learning open-limit and close-limit when power on.
- \* Soft stop before open and close limits.
- \* Automatically Return when encountering resistance.
- \* Protection and access control equipment can be connected, such as radar, infrared sensor, card reader, electromagnetic lock, electric bolt lock, etc.
- \* With Fire alarm linkage interface.

### 5. Installation



---

## 5.1 Installation diagram

### Example for Pulling

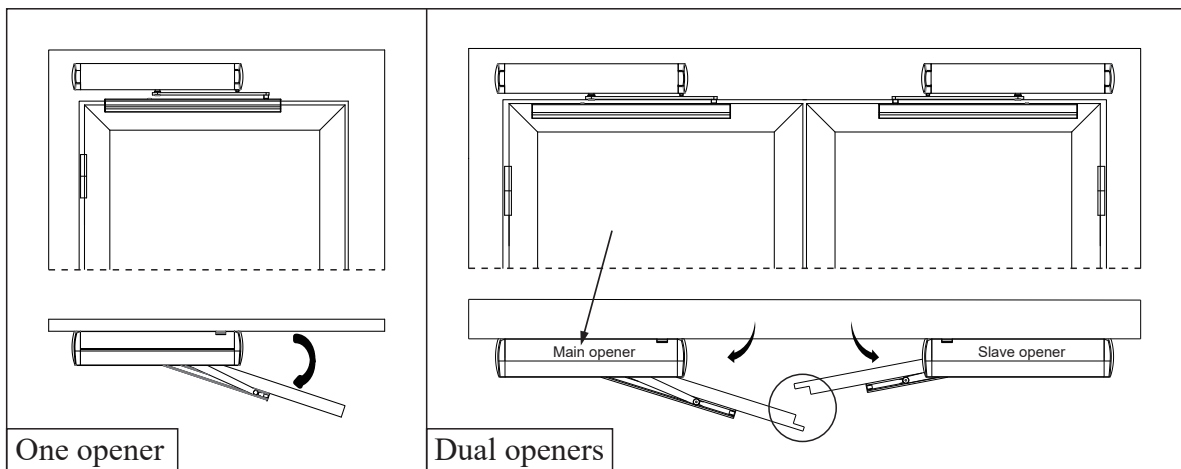

### Example for pushing

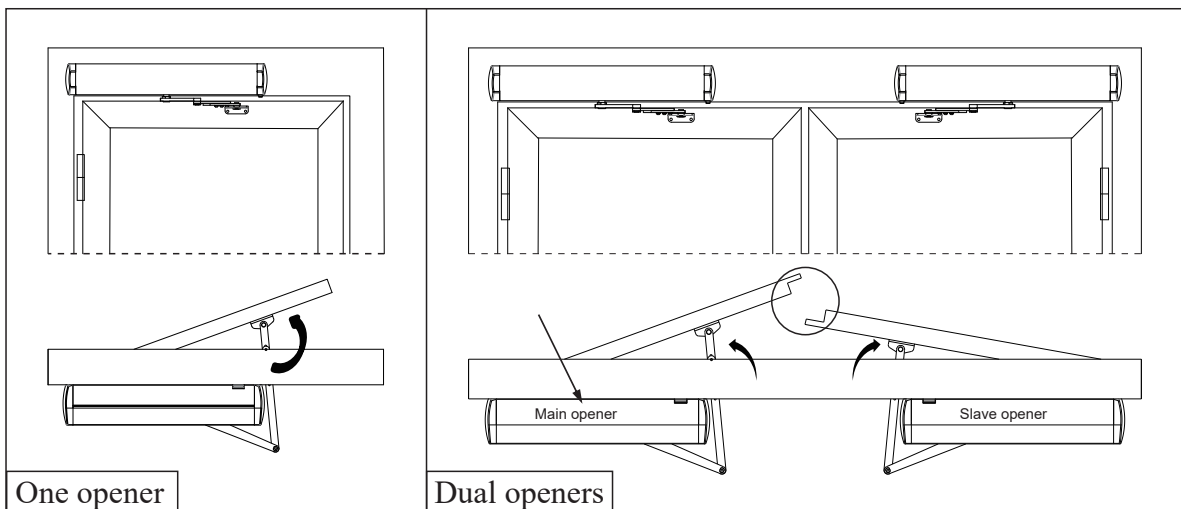

### Very Important Notice!

**Both the door frame and the door must be firm and strong.**

**Ensure the fixed points that the door opener installed on the door frame and the door are firm and reliable, and will not loosen during operation!**

---

## 5.2 Open the Cover before installation

Press one side of the cover to get it out of the slot, and take it out.

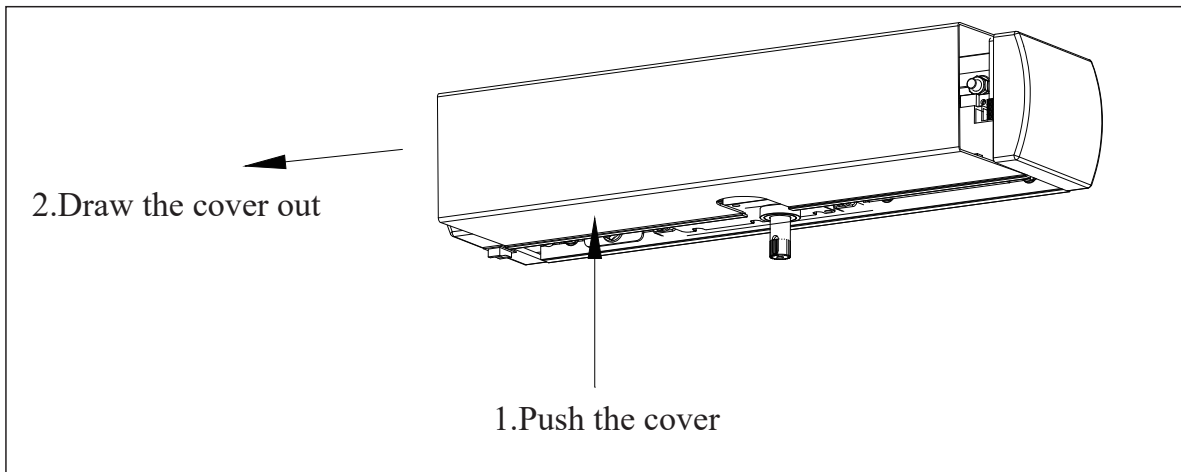

## 5.3 Installation steps of PULLING OPENER

### 5.3.1 Installation location and measurement

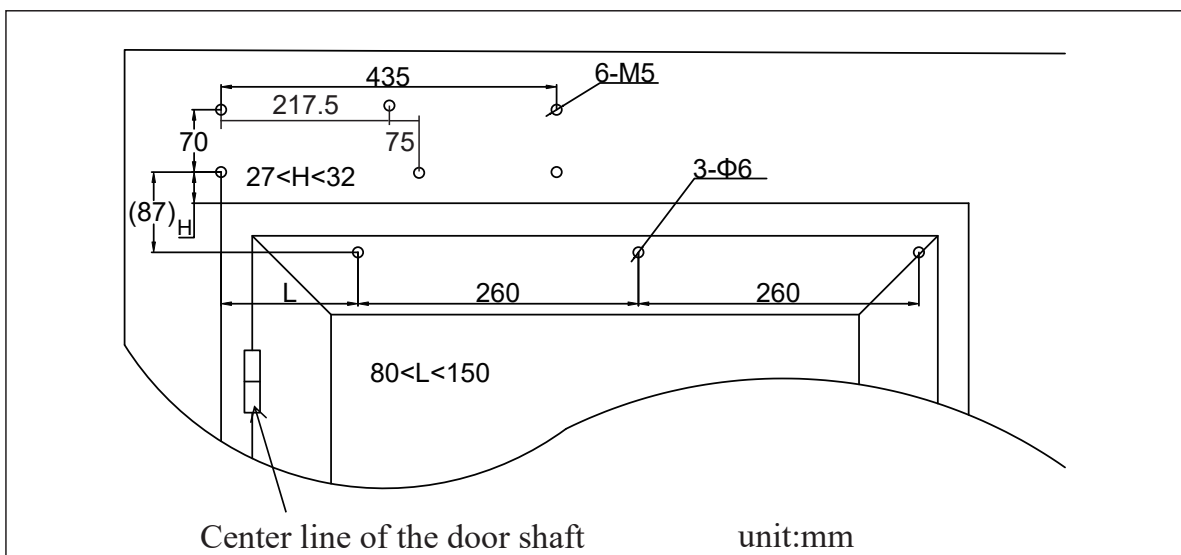

---

### 5.3.2 Installation of OPENER

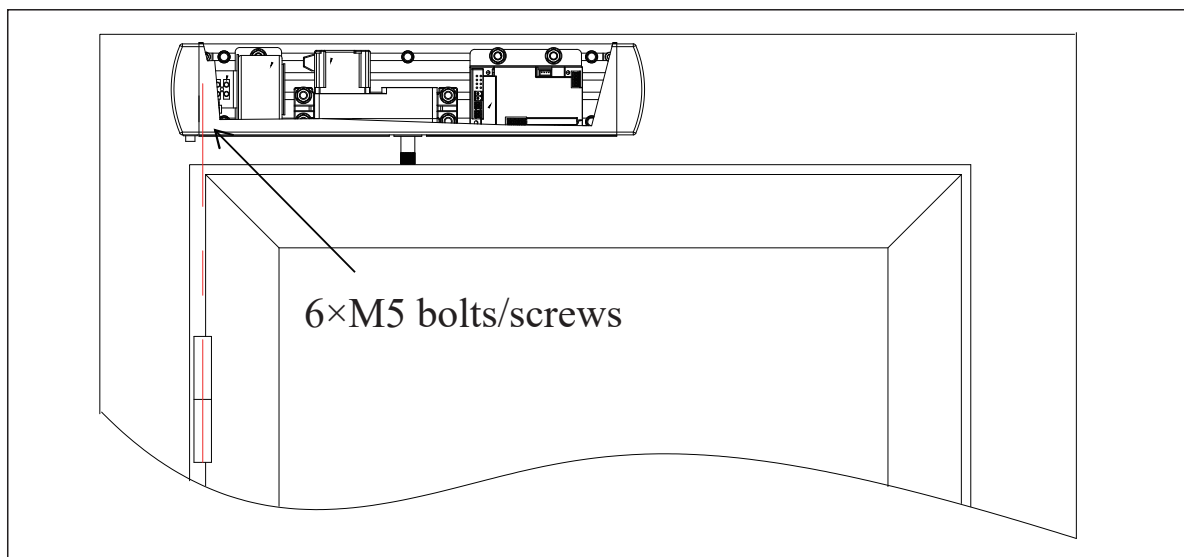

### 5.3.3 Installation of the MAIN ROD

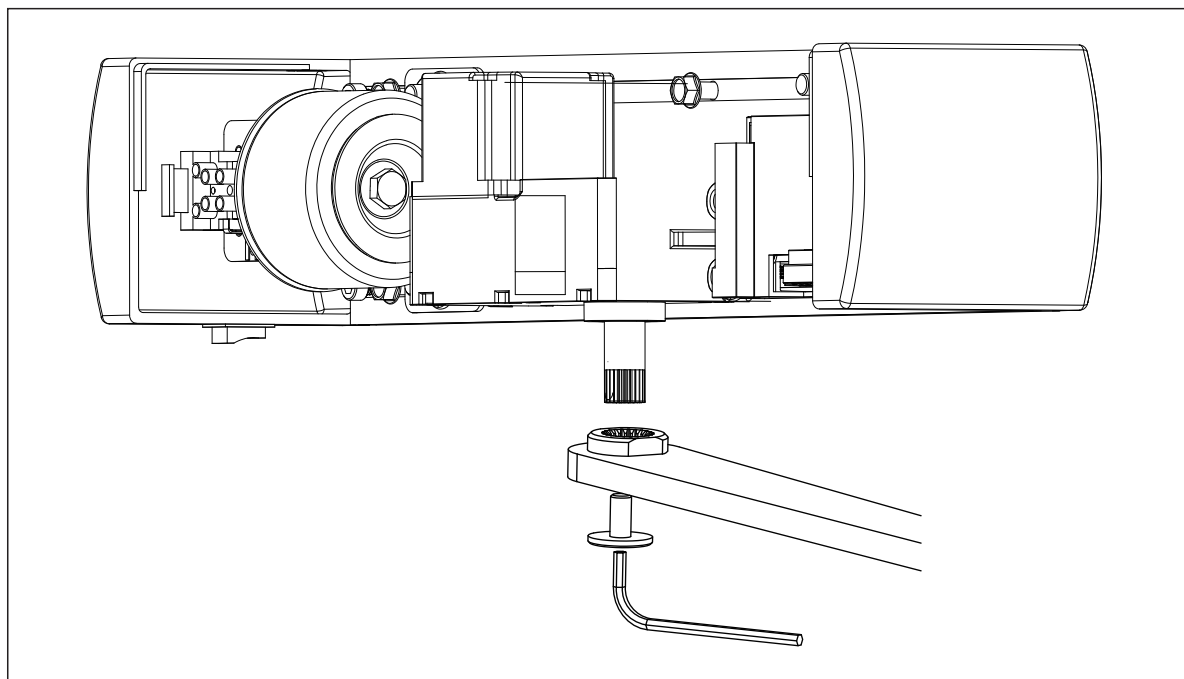

### 5.3.4 Installation of the PULL ROD

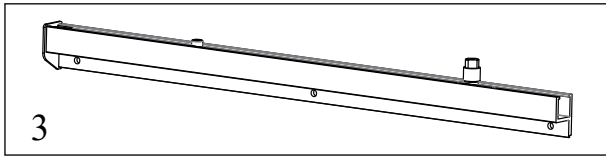
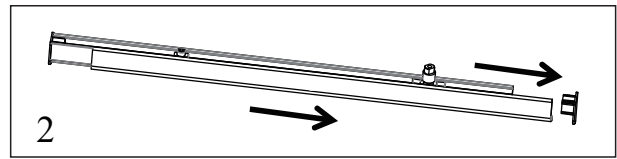
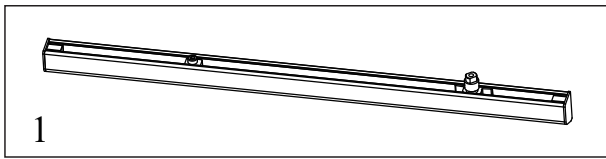

Note: The gap between the lower edge of the main rod from the upper edge of the door must be  $\geq 5$  mm to prevent interference with the door

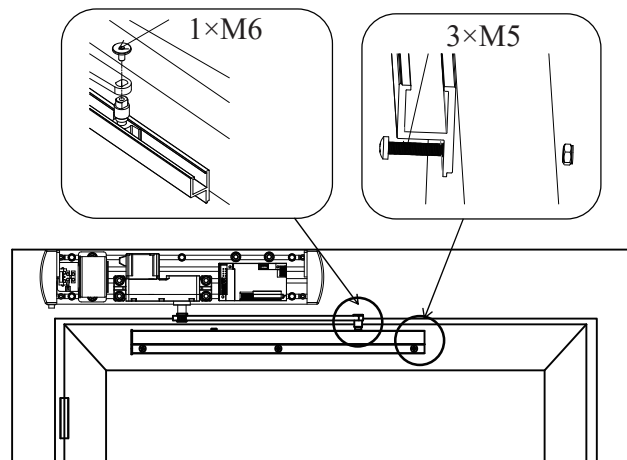

First, use an Allen key to loosen the block screw. Then open the door completely, set the limit stopper about 5mm away from the slider.

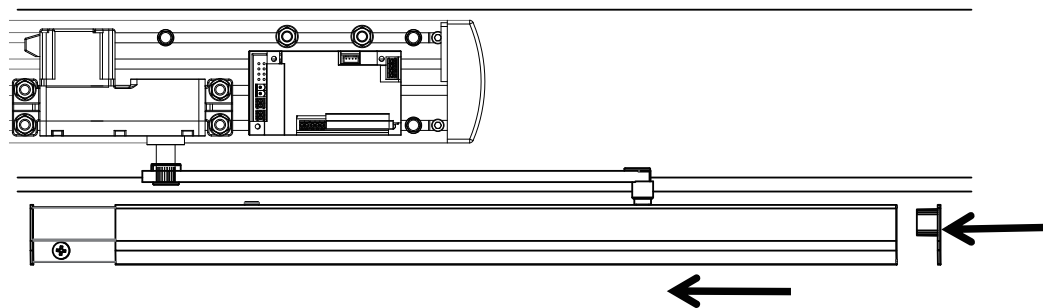
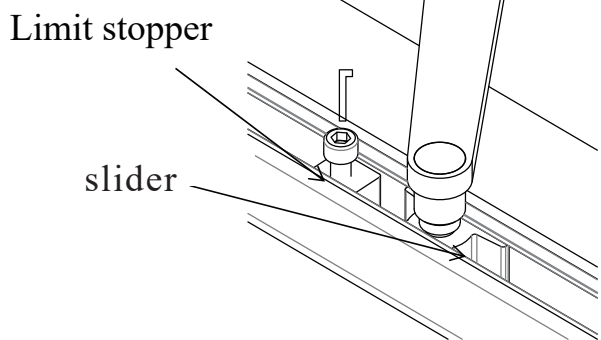



## 5.4 Installation steps of PULLING OPENER

### 5.4.1 Installation location and measurement

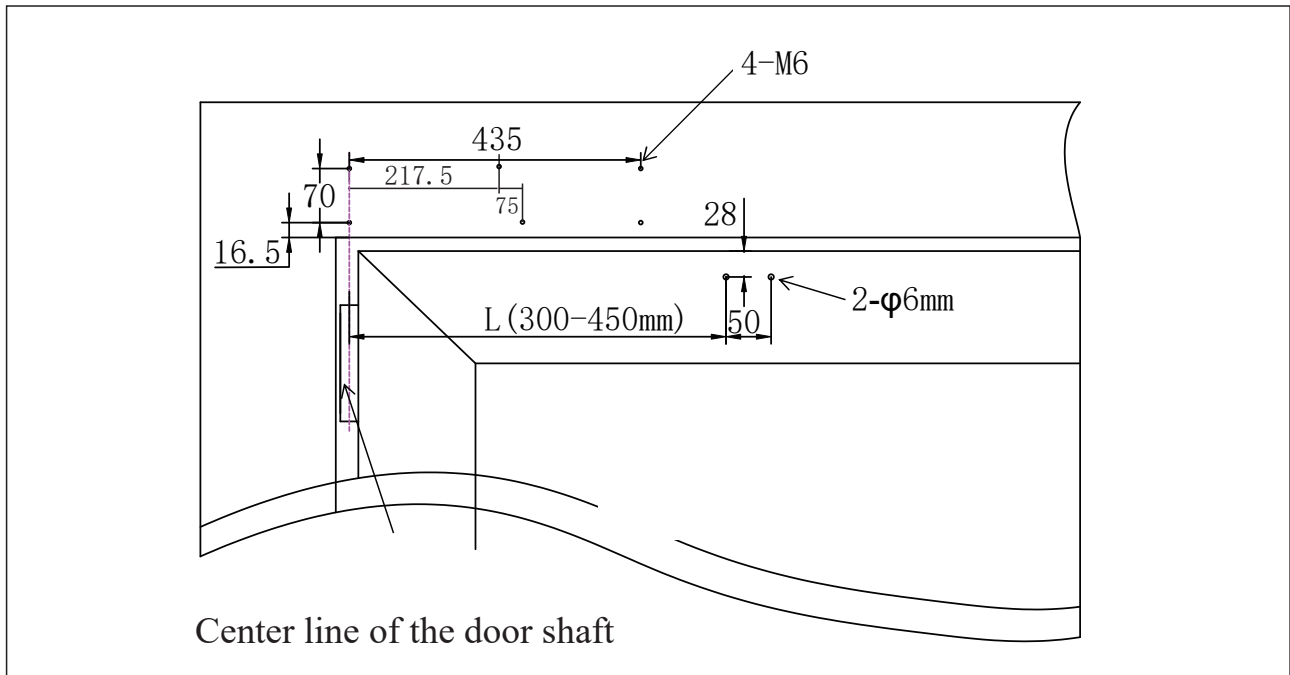

(Installation of OPENER and the MAIN ROD, refer to 5.3.3)

### 5.4.2 Installation of the PUSH ROD

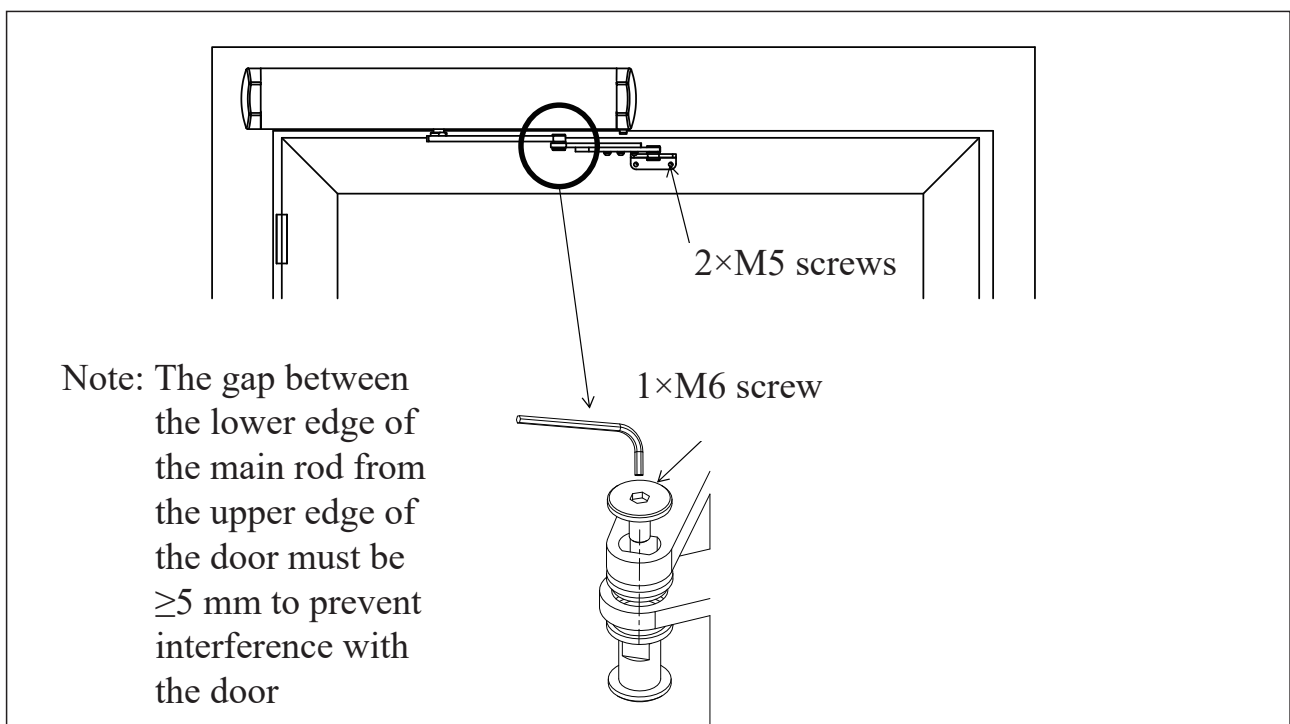

---

## 6.Instruction of DC brushless Swing opener control unit

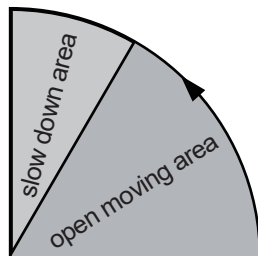

Open operation

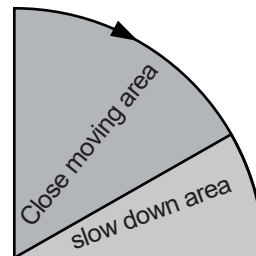

Close operation

### 1、Operate mode

Power on, gate auto close to detect close limit position—stop—

Send Open signal—Opening—Soft stop—To the max travel—Stop,

waiting the auto-close time—Auto-close—Softstop—Stop

### 2. Obstacle mode

Meet obstacle during opening—stop—wait for 3 seconds—Open.

Meet obstacle during closing—stop—wait for 3seconds—Open

### 3. Photocell mode

Activate photocell during closing—Open



---

No	Description	Mark
1	Terminals of motor	
2	Input 24V	
3	light	
4	E-lock	Default is 24V
5	RS485 communication terminal	
6	Red and green light	
11	External signal input terminal	
13	LED display	
14	Operate buttons	Set, add/open, minus/close,quit
15	Learn	Learn button

---

## 8. Operation process

### 8.1 limit learning process

Note: Auto-detect the close position after power on, display value from 30 to 10, don't stop the door during closing, set the open travel by value of F8, if power on, the door is auto-open not auto-close, need to set the value of F6 from .0 to 1, or from 1 to 0.

### 8.2 Function parameter setting

F1	Open speed, range: 15~99, default: 50
F2	Close speed, range: 15~99, default: 40
F3	Soft open speed, range: 5~50, default: 15
F4	Soft close speed, range: 5~50, default: 15
F5	Soft open and soft stop range: 2~8, default: 5
F6	Motor running: Clock-wise or anti clock-wise set, default: 0, 0 means clock wise running, 1 means anti clock-wise running.
F7	Auto close delay time, range: 0~99, default: 5, 0 means off this function.
F8	Open travel, range: 20~60, default: 40, could adjust the open angle of door.
F9	Main motor and slave motor set, 0: main motor, 1: slave motor, 2: single motor.
G1	The time difference between main motor and slave motor, range: 0~10, default: 0, normally fit for the swing doors with door holder
G2	Obstacle current set, range: 10~40, default: 25, unit: 0.1A
G3	Auto lock when door is closed, 0: not lock, 1: lock, default: 1
G4	Auto-detect current setting, range: 3~20, default: 10, unit: 0.1A
G5	Arrive at limit position current set, range: 3~20, default: 8, unit: 0.1A

---

G6	Remote mode:0= four buttons Normal Open mode(Remote: T26) 1=single button cycle control mode(Remote: T23) 2=single button open control mode(Single button switch: WT01)
G7	Photocell function: Default: 0 0 means door will open if photocell is activated during closing. 1 means door will close after 3S if photocell is activated during closing
G8	Motor type: default: 0
G9	Reset: default is 0, adjust the value to 20 is reset all parameters.
H1	Reserved parameter
H2	Reserved parameter
H3	Reserved parameter
H4	Reserved parameter
H5	Reserved parameter
H6	Reserved parameter
H7	Reserved parameter
H8	Open delay time, range: 0~20, default is 0, unit is 0.1s, normally use for e-lock.
H9	Auto-detect default is 0, 0: close, 1: open, 2: randomly open(only for test)

---

## 8.3 Parameter setting

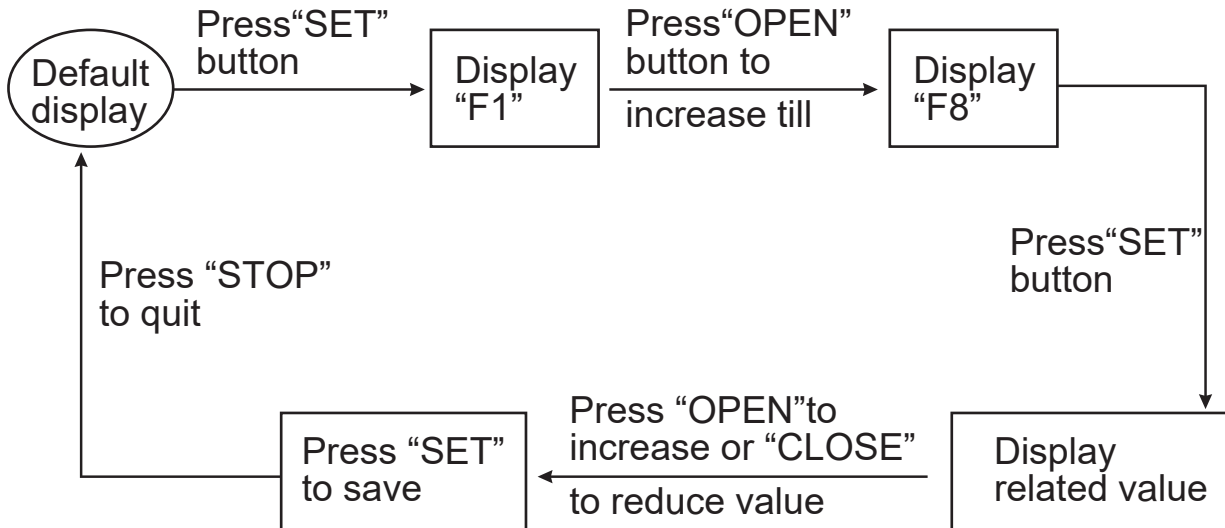

## 8.4 Transmitter's coding and Erasing

### 8.4.1 Transmitter's code setting

Press "LEARN" button on the Control Board to the LED light on, then press the button which you choose on the transmitter till the LED flashes and goes out. Now, the transmitter is coded. Other transmitters can be coded as this way.

### 8.4.2 Erasing the transmitter's code

Press "LEARN" button on the Control Board and hold on to make the "LEARN LED" light on up to go out. Now, all transmitters which had been coded are cleared.

## 9. Trouble and shooting

### 9.1 Error code list

<b>Error Code</b>	<b>Meaning</b>	<b>Shooting</b>
E1	motor is abnormal	Check the motor wire and connection
E2	Operate overtime	Check if the motor is moving smoothly or not.
E3	Obstacle during opening	Check if the motor is moving smoothly or not.
E4	Obstacle during closing	Check if the motor is moving smoothly or not.
E5	Voltage is too low	Check input power
E6	Photocell is blocked for a long time	Remove the obstacle
E7	Limit position is abnormal	Restart power then motor will auto-inspection.
<b>others</b>	<b>Meaning</b>	<b>Introduction</b>
No	door is Normal Open	
3..2..1..	Closing countdown	0 means close
Default: 30-10	door position	10 is the door position
Flash display 0/1/2	Display value of F9, means main/slave/single motor	0 is main motor, 1 is slave motor 2 is single motor



## 9.2 Trouble Shooting

<b>Trouble</b>	<b>Reason</b>	<b>Shooting</b>
No display after power on	No input power	Check input power
	Power line is wrong connected	Check the connections
	Fuse protect	Check if there is a short circuit.
Display Error code	Refer to Error list	Refer to Error list
Remote doesn't work	Battery is no power	Change a new battery
	Single is weak	Keep away from the obstacles or interference source.
	Water gets into remote Or remote is damaged	Change a new remote
Motor is not running	Motor wire is short circuit.	Check the wire and connection
Door running direction is opposite to control	The value of F6 is incorrect	Reset vale of F6
Swing doors are not running simultaneously	Main and slave motor are set incorrect	Reset value of F9
Open and close position are not correct	Door is obstacle when learning limit	Restart power then learn limit.
Power on, the door is stop not reach limit switch after auto-detect closing	Auto-detect current is set to little	Increase the value of G4
Door doesn't close to limit position	Arrive at limit position current is set to little	Increase the value of G5

